

Air Sync Air Remote User's Guide EN

This user guide is available in other languages at profoto.com/support

CN – 其他语言版本的用戶指南可从profoto.com/cn/support下载

DE – Das Bedienungs-Handbuch is auch in anderen Sprachen verfügbar unter profoto.com/de/support

ES – Esta guía de usuario está disponible en otros idiomas en profoto.com/support

FR – Ce manuel d'utilisation est également disponible en d'autres langues sur profoto.com/fr/support

IT – Questa guida per gli utenti è disponibile in altre lingue su profoto.com/it/support

JP – このユーザーガイドはprofoto.com/ja/supportに他の言語でもご用意しています。

RU – Инструкция пользователя на других языках доступна на profoto.com/ru/support





Thank you for choosing Profoto

Thanks for showing us your confidence by investing in a Profoto Air device. For more than four decades we have sought the perfect light. What pushes us is our conviction that we can offer even yet better tools for the most demanding photographers. Before our products are shipped we have them pass an extensive and strict testing program. We check that each individual product comply with specified performance, quality and safety. For this reason our flash equipment is widely used in rental studios and rental houses worldwide, from Paris, London, Milan, New York, Tokyo to Cape Town.

Professional photographers around the world have come to value Profoto's expertise in lighting and light-shaping. Our extensive range of Light Shaping Tools offers photographers unlimited possibilities for creating and adjusting their own light.

Every single reflector and accessory creates its special light and the unique Profoto focusing system offers you the possibility to create your own light with only a few different reflectors.

Enjoy your Profoto product!

Safety instructions



SAFETY PRECAUTIONS!

Do not operate the equipment before studying the instruction manual and the accompanying safety. Make sure that Profoto Safety Instructions is always accompanied the equipment! Profoto products are intended for professional use! Generator, lamp heads and accessories are only intended for indoor photographic use. Do not place or use the equipment where it can be exposed to moisture, extreme electromagnetic fields or in areas with flammable gases or dust! Do not expose the equipment to dripping or splashing. Do not place any objects filled with liquids, such as vases, on or near the equipment. Do not expose the equipment to hasty temperature changes in humid conditions as this could lead to condensation water in the unit. Do not connect this equipment to flash equipment from other brands. Do not use flash heads without supplied protective glass covers or protective grids. Glass covers shall be changed if it has become visibly damaged to such an extent that their effectiveness is impaired, for example by cracks or deep scratches. Lamps shall be changed if they are damaged or thermally deformed. When placing a lamp into the holder ensure not to touch the bulb with bare hands. Equipment must only be serviced, modified or repaired by authorized and competent service personnel! Warning - The terminals marked with the flash symbol are hazardous live.



WARNING – Electrical Shock – High Voltage!

Mains powered generator shall always be connected to a mains socket outlet with a protective earthing connection! Only use Profoto extension cables! Do not open or disassemble generator or lamp head! Equipment operates with high voltage. Generator capacitors are electrically charged for a considerable time after being turned off. Do not touch modeling lamp or flash tube when mounting umbrella metal shaft in its reflector hole. Disconnect lamp head cable between generator and lamp head when changing modeling lamp or flash tube! The mains plug or appliance coupler is used as disconnect device. The disconnect device shall remain readily operable. Batteries (battery pack or batteries installed) shall not be exposed to excessive heat such as sunshine, fire or the like.



Caution – Burn Hazard – Hot Parts!

Do not touch hot parts with bare fingers! Modeling lamps, flash tubes and certain metal parts emit strong heat when used! Do not point modeling lamps or flash tubes too close to persons. All lamps may on rare occasions explode and throw out hot particles! Make sure that rated voltage for modeling lamp corresponds with technical data of user guide regarding power supply!

NOTICE

NOTICE – Equipment Overheating Risk

Remove transport cap from lamp head before use! Do not obstruct ventilation by placing filters, diffusing materials, etc. over inlets and outlets of the equipment ventilation or directly over glass cover, modeling lamp or flash tube!

Note about RF!

This equipment makes use of the radio spectrum and emits radio frequency energy. Proper care should be taken when the device is integrated in systems. Make sure that all specifications within this document are followed, especially those concerning operating temperature and supply voltage range. Make sure the device is operated according to local regulations. The frequency spectrum this device is using is shared with other users. Interference can not be ruled out.



Final Disposal

Equipment contains electrical and electronic components that could be harmful to the environment. Equipment may be returned to Profoto distributors free of charge for recycling according to WEEE. Follow local legal requirements for separate disposal of waste, for instance WEEE directive for electrical and electronic equipment on the European market, when product life has ended!

Package contents



Profoto Air Sync (90 10 32)



Profoto Air Remote (90 10 31)



Profoto Air Sync Kit (90 10 35)

Table of Contents

System description	8
Profoto Air products	8
Profoto Air Remote.....	8
Profoto Air Sync.....	8
Profoto Air USB.....	8
Profoto Studio Air.....	8
Nomenclature	9
Applications	10
Remote control.....	10
Remote camera release.....	10
Relay.....	11
Functions	12
Transmit/Receive mode selection.....	12
Channel selection	12
Group selection.....	12
Remote control	12
Master mode	13
Command confirmation	13
Test function.....	13
Fast mode	13
Auto Power Off	13
Connections.....	13
Batteries.....	14
Operating instructions.....	15
Remote flash Synchronization.....	15
Release of remote camera	18
Relay	21
Additional functions	23
Technical data	24
Profoto Air Remote.....	24
Regulatory Information	25
World-wide Usage of Radio Spectrum	25
EU Declaration of Conformity	26
Unites States and Canada	27
F.C.C. and Industry Canada	27
Japan	28

System description

Profoto Air is a wireless system for convenient remote control of both your camera and your flash equipment. The small and lightweight Profoto Air device gives you full freedom of movement, allowing you to concentrate on the creative side of your work.

The Profoto Air system is operating on one of eight selectable radio channels on the 2.4 GHz radio frequency band, for world wide use.

Profoto Air products

All Profoto flash generators with Profoto Air inside can be controlled via the Profoto Air system.

8

Profoto Air Remote

The Profoto Air Remote offers complete generator control at your camera or in your hand, including flash energy and modeling light control. The device controls practically an infinite number of generators in up to six groups, either all at once in Master mode, or in individual groups. Profoto Air Remote also allows remote camera release and flash synchronization.

Profoto Air Sync

Profoto Air Sync allows remote camera release and flash synchronization of practically an infinite number of generators, with the same high performance as Profoto Air Remote.

Profoto Air USB

The Profoto Air USB device is a USB 2.0 transceiver, which connects your flash generators with integrated Profoto Air functionality to your PC or Mac via a wireless connection. Profoto Air USB allows control of your light from as far away as 300 m/1000 ft (free line of sight).

Profoto Studio Air

Profoto Studio Air is a software solution for both PC and Mac, which gives you full control of all your generators and lamp heads from your computer. You can control each lamp head individually or group them to control multiple heads or packs at one time. You can save customer lighting setups for use at a later time.



Nomenclature

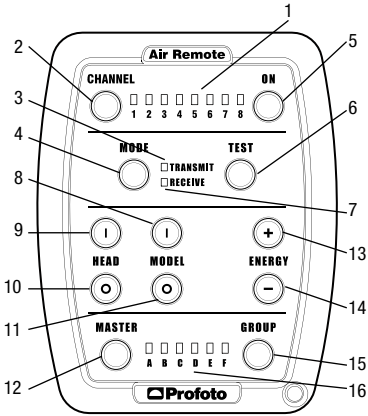

Profoto Air Remote

1. Channel Indicators
2. Channel Button
3. Transmit Indicator
4. Mode Button
5. On Button
6. Test Button
7. Receive Indicator
8. Model Button I
9. Head Button I
10. Head Button O
11. Model Button O
12. Master Button
13. Energy Button +
14. Energy Button -
15. Group Button
16. Group Indicators
17. In Connector
18. Out Connector
19. Hot Shoe Connector

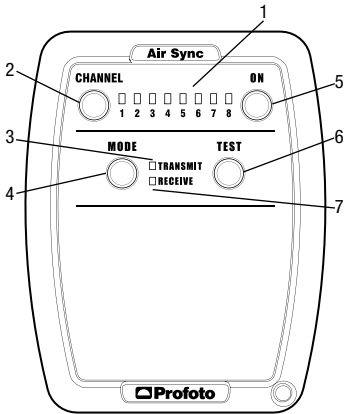

Profoto Air Sync

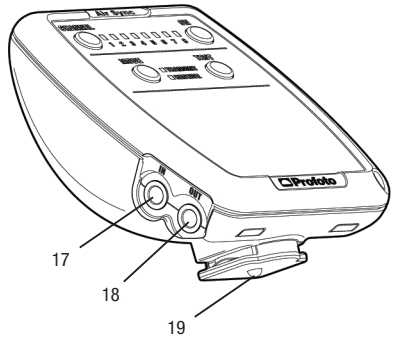

Connections

Applications

Synchronization

Both the Profoto Air Sync and Profoto Air Remote devices can be used to remotely synchronize flash generators. All Profoto Air generators that have the same radio channel set will be synchronized simultaneously. For generators that do not have a built-in Profoto Air receiver, a Profoto Air device can be connected and used as receiver.

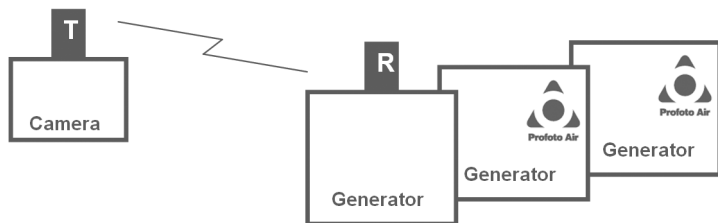

10

Remote control

Profoto Air Remote can be used for remote control of generators with built-in Profoto Air functionality.

Instead of pressing buttons and turning controls on the generator, settings and functions can be adjusted from the Profoto Air Remote device. It is possible to remotely control the power settings of lamp heads, turn the lamp heads on/off and turn the modeling light on/off. Changes made with Profoto Air Remote take immediate effect on the generator.

By the use of groups, selected lamp heads on one or several generators can be controlled simultaneously with Profoto Air Remote. Group selection allows a large light bank with several lamp heads, for example the background light, to be controlled as one light source.

Remote camera release

Both Profoto Air Sync and Profoto Air Remote devices can be used to remotely release a camera.

For wireless remote release, one Profoto Air device, acting as receiver, is connected to the camera and another Profoto Air device is used as transmitter of the release signal.



Relay

Both Profoto Air Sync and Profoto Air Remote devices can be used to remotely release a camera and automatically flash the generator(s) in sync with the camera.

Two Profoto Air devices are connected to the camera, one acting as receiver of the release signal from the handheld Profoto Air device and the other acting as transmitter of the sync signal to the generator. Different radio channels are used for the release and sync signaling.

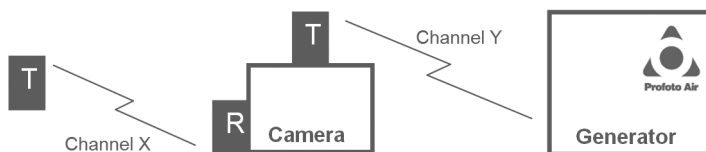

Functions

Transmit/Receive mode selection

The Mode Button [4] is used to set the Profoto Air device to transmitter or receiver. The Transmit Indicator [3] and the Receive Indicator [7] indicates the selected mode.

Channel selection

Channel selection is used to select one of eight specific frequencies in the 2.4 GHz band. The frequencies are evenly spread over the entire frequency band, to optimize reliable functionality. The large number of radio channels makes it possible to select a channel that is not interfered by other photographers using Profoto Air, or by WLAN and Bluetooth devices and other radio equipment operating on the same widely used 2.4 GHz frequency band.

For synchronization and/or remote control of one or several generators, the same radio channel shall be set on all generators and on the Profoto Air device(s). For remote camera release, the same channel shall be set on both Profoto Air devices (transmitter and receiver.)

Channel selection on the Profoto Air Sync and Profoto Air Remote devices is made with the Channel Button [2]. The Channel Indicator [1] corresponding to the selected radio channel (1-8) is illuminated.

Group selection

Groups are used to allow remote radio control of selected generator lamp heads. All lamp heads that are assigned to the same group will be controlled simultaneously. The lamp heads on a generator can be assigned to different groups. Lamp heads on different generators can be assigned to the same group.

Group selection on the Profoto Air Remote device is made with the Group Button [15]. The Group Indicator [16] corresponding to the selected radio group (A-F) is illuminated. The Master Button [12] is used to select all groups.

Remote control

Remote radio control is available for generators with built-in Profoto Air functionality.

For remote radio control, both the Channel and Group settings on the Profoto Air Remote device must match the Channel and Group settings of the lamp heads in the group.

The Head Button 1 [9] is used to turn on the flash lamp heads.
The Head Button 0 [10] is used to turn off the flash lamp heads.

The Model Button 1 [8] is used to turn on the modeling light.
The Model Button 0 [11] is used to turn off the modeling light.

The Energy Button + [13] is used to increase the energy level.
The Energy Button - [14] is used to decrease the energy level.

Press the Energy Button < 2 seconds to adjust the energy level in 1/10 f-stop increments. Press the Energy Button > 2 seconds to adjust the energy level in 1 f-stop increments.

If the energy level of any flash lamp head in the group is in minimum or maximum position, all energy levels will remain unchanged; see section *Command confirmation* below.

Master mode

In Master mode, the same remote control command is sent to all Groups on the selected Channel.

With the Master Button [12] on the Profoto Air Remote device, all Groups are selected and will be affected by the remote control commands.

Command confirmation

If an energy level cannot be set by the generator as commanded, because the energy of a lamp head is set to minimum or maximum level, the Profoto Air Remote device will make an acoustic sound to signal that the command was not executed. The energy level of all flash lamp heads in the group will remain unchanged.

Test function

The Test Button [6] is used to manually transmit a sync signal, verifying expected functionality, for remote camera release or flash triggering.

The Test Button [6] is also used to transmit the release signal, for remote camera release. If the camera is set up in single mode, there will be one single shot when the Test Button [6] is pressed. If the camera is set up for continuous mode, the camera will continue shooting as long as the Test Button [6] is held down. Because of a lag effect, the camera might take a few more shots after the Test Button [6] has been released.

Fast mode

The Profoto Air Sync and Profoto Air Remote devices deliver sync signals with a very short delay. In Fast mode, the delay is even shorter. Fast mode is only recommended when working with very short camera shutter times, as the battery consumption is considerably higher. In Fast mode, the remote control functionality (available in Profoto Air Remote) is disabled and inoperative. For more information, see last section on Additional functions.

Auto Power Off

The Profoto Air device is automatically turned off after 30 minutes of inactivity. The Auto Power Off function is possible to disable. For more information, see last section on Additional functions.

Connections

When the Profoto Air Sync or Profoto Air Remote device is used as a transmitter to remotely synchronize flash generators and speedlights, the device shall be connected to the camera via the Hot Shoe Connector [19] or via a cable connected to the In Connector [17].

When the Profoto Air device is used as a receiver for remote flash synchronization, the device shall be connected to the generator's sync input socket or to the speedlight's PC terminal via a cable connected to the Out Connector [18].

For remote camera release in single mode, the Profoto Air Sync or Profoto Air Remote device shall be connected to the camera via a cable connected to the Out Connector [18].

For remote camera release in continuous mode, the Profoto Air Sync or Profoto Air Remote device shall be connected to the camera via a cable connected to the In Connector [17].

Batteries

The Profoto Air Sync and Profoto Air Remote devices are powered by two standard AAA batteries.

Operating instructions

Remote flash Synchronization

Profoto Air devices can be used to remotely synchronize flash generators and various speedlights equipped with a PC terminal.

Camera setup

Connect the Profoto Air device to the camera, using one of the following methods:



a) Slide the Hot Shoe Connector [19] on the Profoto Air device into the camera's hot shoe.



b) Connect a sync cable from the camera to the In Connector [16] on the Profoto Air device.

Generator setup (*without built-in Profoto Air*)

1. Connect the Profoto Air device to the generator, via a cable from the Out Connector [18] on the device to the sync input socket on the generator or the PC terminal on the speedlight.
2. Press and hold down the On Button [5] to turn on the Profoto Air device.
3. Press the Channel Button [2] until the desired Channel Indicator [1] is illuminated. The selected channel shall be the same for all generators.
4. Press the Mode Button [4] and verify that the Receive Indicator [7] is illuminated.
5. For proper setup when using a speedlight, consult the user manual of the actual speedlight.



Generator setup (with built-in Profoto Air)

1. Set the generator to synchronization via radio.
2. Select the same radio channel on all generators.

Synchronization

1. Press and hold down the On Button [5] to turn on the Profoto Air device on the camera.
2. Verify that the Transmit Indicator [3] is illuminated.
3. Press the Channel Button [2] until the desired Channel Indicator [1] is illuminated. The selected channel shall be the same as the radio channel setting on the generators and/or speedlights.
4. Press the Test Button [6] to verify that the generators and/or speedlights flash as expected.

Remote generator control

Generators with built-in Profoto Air functionality can be remotely controlled with a Profoto Air Remote device.

Generator setup

1. Set the generator to synchronization via radio.
2. Select the same radio channel on all generators.
3. Select the same group settings for all lamp heads that shall be controlled simultaneously.

Profoto Air Remote setup

1. Press and hold down the On Button [5] to turn on the Profoto Air Remote device.
2. Verify that the Transmit Indicator [3] is illuminated.
3. Press the Channel Button [2] until the desired Channel Indicator [1] is illuminated. The selected channel shall be the same as the radio channel setting on the generators.
4. Press the Group Button [15] until the desired Group Indicator [16] is illuminated. The selected group shall be the same as the group setting for the lamp heads to be controlled.

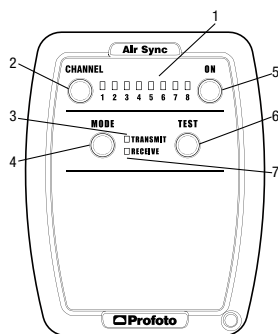



Selecting a group

Press the Group Button [15] until the Group Indicator [16] corresponding to the group of lamp heads to control is illuminated.

Selecting all groups

Press the Master Button [12] to select all groups.

Turning lamp heads on/off

Press the Head Buttons [9] and [10] to turn on/off all flash lamp heads in the selected group(s).

Turning modeling light on/off

Press the Model Buttons [8] and [11] to turn on/off the modeling light in the selected group(s).

Changing energy level

Use the Energy Buttons [13] and [14] to increase/decrease the energy level of the selected group(s):

- Press the Energy Button < 2 seconds to increase/decrease in 1/10 f-stop increments.
- Press the Energy Button > 2 seconds to increase/decrease in 1 f-stop increments.

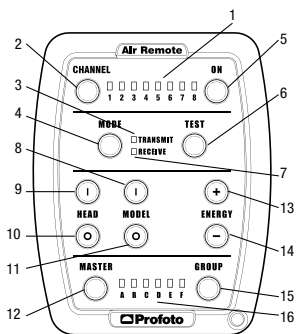

Release of remote camera

Two ProfotoAir devices (receiver and transmitter) can be used for wireless remote camera release. In this case, the camera has to be equipped with an electronic shutter release connection.

Camera setup

1. For a single shot, set the camera to single mode. If the camera is set to continuous mode, the camera will continue shooting as long as the Test Button [6] is held down. Continuous mode is recommended for shooting with 2 fps or faster.
2. Connect a camera release cable corresponding to the camera in use (Canon, Hasselblad, Nikon, Phase One, ...) from the camera to the [In Connector](#) [17] on the ProfotoAir device.



Note!

If releasing camera in single mode and more than 2 fps is needed, the cable from the camera should be connected to the [Out Connector](#) [18] on the ProfotoAir device. This connection is only recommended if the camera is set to manual focus or if a pre-release cable is used to connect the camera and the unit. For more information on pre-release functionality, see section on [Camera release cables](#).

Receiver setup

This section applies to the Profoto Air device used as receiver for both wireless remote camera release and remote camera release via cable.

1. Press and hold down the On Button [5] to turn on the Profoto Air device used as receiver.
2. Press the Channel Button [2] to select a radio channel, as indicated by the Channel Indicator [1].
3. Press the Mode Button [4] and verify that the Receive Indicator [7] is illuminated.

Releasing camera wirelessly

1. Press and hold down the On Button [5] to turn on the handheld Profoto Air device used as transmitter.
2. Verify that the Transmit Indicator [3] is illuminated.
3. Press the Channel Button [2] until the same Channel Indicator [1] as on the Profoto Air device connected to the camera is illuminated.
4. Press and hold down the Test Button [6] until the camera is released.

Releasing camera via cable

With only one Profoto Air device connected via cable to the camera, the unit can be used to remotely release the camera by wire.

1. Press and hold down the Test Button [6] on the Profoto Air device connected to the camera until the camera is released.



Camera release cables

There are two different kinds of release cable for remote camera release; release cables and pre-release cables.

A regular release cable let's you connect your camera to your Profoto Air unit for remote camera release. The pre-release cables have a switch to activate pre-release mode. With the pre-release function activated, the switch keeps the camera awake for faster response. This works just like continuous halfway pressing of the release button on the camera.

Relay

Profoto Air devices can be used to remotely release a camera and automatically flash the generator(s) in sync with the camera. The camera has to be equipped with an electronic shutter release connection.

Camera setup

1. For a single shot, set the camera to single mode. If the camera is set to continuous mode, the camera will continue shooting as long as the Test Button [6] is held down.
2. Connect one Profoto Air device (receiver) to the camera, using a camera release cable corresponding to the camera in use connected to the In Connector [17].
3. Turn on the Profoto Air device (receiver) and ensure that the Receive Indicator [7] is illuminated.
4. Press the Channel Button [2] to select a radio channel.
5. Connect another Profoto Air device (transmitter) to the camera, via the Hot Shoe Connector [19] or via the In Connector [17].



6. Turn on the Profoto Air device (transmitter) and ensure that the Transmit Indicator [3] is illuminated.
7. Press the Channel Button [2] to select a radio channel. The channel must be different from the channel selected on the Profoto Air device used as receiver.

Generator setup (without built-in Profoto Air)

1. Connect a Profoto Air device to the generator, via a cable from the Out Connector [17] on the device to the sync input socket on the generator.
2. Turn on the Profoto Air device and ensure that the Receive Indicator [7] is illuminated.
3. Select the same radio channel as on the Profoto Air device acting as transmitter on the camera.

**Generator setup (with built-in Profoto Air)**

1. Set the generator to synchronization via radio.
2. Select the same radio channel as on the Profoto Air device acting as transmitter on the camera.

Releasing and relaying

1. Turn on the handheld Profoto Air device and verify that the Transmit Indicator [3] is illuminated.
2. Select the same radio channel as on the Profoto Air device acting as receiver on the camera.
3. Press and hold down the Test Button [6] until the camera is released and the generator(s) flash.



Additional functions

Fast mode

Fast mode is used when an extra short sync signal delay is required.

1. To enter Fast mode, press and hold down the Mode Button [4] for 7 seconds, until there is a beep and the Transmit Indicator [3] starts to blink fast.
2. To exit Fast mode, press the Mode Button [4] once.

Silent mode

This section only applies to the Profoto Air Remote device.

1. Ensure that the Profoto Air device is turned off.
2. To enter Silent mode, press and hold down the Head Button 0 [10] and the On Button [5] simultaneously until the Transmit Indicator [3] is illuminated.
3. Silent mode is automatically disabled when the device is turned off.

Disable Auto Power Off

1. Ensure that the Profoto Air device is turned off.
2. To disable the Auto Power Off function, press and hold down the Mode Button [4] and the On Button [5] simultaneously. When deactivating the auto power off function, the device confirms this with a short beep immediately.
3. The Auto Power Off function is automatically enabled when the device is turned off.

Factory settings

1. Ensure that the Profoto Air device is turned off.
2. To reset the Profoto Air device to factory settings, press and hold down the Test Button [6] and the On Button [5] simultaneously until there are three beeps.

Technical data

Profoto Air Remote

Profoto Air Sync

Specifications

Frequency band	2.4 GHz
Separate radio channels	8
Group/radio channels	6
Range	Range Up to 300 m (1000 ft) (free line of sight)
Battery type	2 x AAA
Typical battery lifetime Transmit mode Fast/Normal	10 hrs/140 hrs
Typical battery lifetime Receive mode	30 hrs
Sync delay, Fast/Normal mode	200 μ s/465 μ s
Antenna type	Integrated
Auto power off	30 min of inactivity
Sync signal in	ISO 518 hot shoe and 3,5 mm phone plug
Sync signal out	3,5 mm phone plug

Measurements

Dimensions	70 x 50 x 40 mm (2,7 x 1,9 x 1,6 in)
Weight with/without battery	40 g/70 g (1,4 oz/2,5 oz)

All data are to be considered as nominal and Profoto reserves the right to make changes without further notice.

Regulatory Information

World-wide Usage of Radio Spectrum

The Profoto Air Sync and Profoto Air Remote operates on the license-free 2.4GHz ISM band for SRD (Short Range Devices). This band may be used in most parts of the world. Regional restrictions may apply.



Note!

Refer to national regulations for the region where the Profoto Air Sync or Profoto Air Remote unit shall be operated and make sure that they are followed

EU Declaration of Conformity

In accordance with the Radio and Telecommunications Terminal Equipment Act and Directive 1999/5/EC (R&TTE Directive)

Manufacturer: Profoto AB
Address: Box 2023, 128 21 SKARPNÄCK, Sweden
Product: 2.4GHz SRD communication module
Type: Profoto Air Remote, Profoto Air Sync, Profoto Air USB

Profoto declares that the product complies with the essential requirements of §3 and the other relevant provisions of the FTEG (Article 3 of the R&TTE Directive) when used for its intended purpose.

26

Harmonised standards applied:

Air Interface of the radio systems pursuant to article 3(2)
EN 300 328

Protection requirements concerning electromagnetic compatibility according to article 3(1)b:
EN 301 489-1, EN 301 489-17, EN 61000-4-3

Skarpnäck, 2009-03-02



Bo Dalenius, VP Technology and QA
Profoto AB

Unites States and Canada F.C.C. and Industry Canada

Compliance Statement (Part 15.19)

This device complies with Part 15 of FCC rules and RSS-210 of Industry Canada.

Operation is subject to the following two conditions:

- 1) this device may not cause harmful interference and,
- 2) this device must accept any interference received, including interference that may cause undesired operation.



Warning (Part 15.21)

Changes or modifications not expressly approved by the party responsible for compliance could void the user's authority to operate the equipment.

27

Ce dispositif est conforme aux normes RSS-210 d'Industrie Canada.

L'utilisation de ce dispositif est autorisée seulement aux conditions suivantes :

- 1) il ne doit pas produire de brouillage et
- 2) l'utilisateur du dispositif doit être prêt à accepter tout brouillage radioélectrique reçu, même si ce brouillage est susceptible de compromettre le fonctionnement du dispositif.

The term 'IC' before the certification/registration number only signifies that the Industry Canada technical specifications were met.

Les lettres 'IC' n'ont aucune autre signification ni aucun autre but que d'identifier ce qui suit comme le numéro de certification/d'enregistrement d'Industrie Canada.

Profoto AB

Transmitter / Receiver

MODEL: Profoto Air Sync

PRODUCT NO: PCA5108-0000

MODEL: Profoto Air Remote

PRODUCT NO: PCA5102-0000

MODEL: Profoto Air USB

PRODUCT NO: PCA5104-0000

FCC ID: W4G-RMI

IC: 8167A-RMI

Made in Sweden

Japan

The module has been granted modular approval for sale and operation in Japan.

特定無線設備の種類

Classification of specified radio equipment:

Article 2, Clause 1, Item 19

2.4 GHz Wide Band Low Power Data Communication

上記のとおり、電波法第38条の24第1項の規定に基づく認証を行ったものであることを証する。

This is to certify that the above-mentioned certification by type has been granted in accordance with the provisions of Article 38-24, Paragraph 1 of the Radio Law.



® 202WW08109202

® 202WW08109203

® 202WW08109204

Technical data and product information are subject to change without notice.

344091-2. Printed in Sweden.

Profoto AB

P.O. Box 1264

SE-172 25 Sundbyberg, SWEDEN

Visiting address:

Landsvägen 57, Sundbyberg

Phone +46 8 447 53 00

info@profoto.com

www.profoto.com



Profoto®
The light shaping company™